



SMOBIMAX 1B



1.400 m³/h

SMOBIMAX	Kw/HP	V	Hz	%	dB	elettr.	m ²	Kg Carb
SMOBIMAX1B	2/3	400	50	95	74	3P+T	10	16
SMOBIMAX1B-EX	2/3	400	50	95	74	3P+N+T	10	16
SMOBIMAX1B200	2/3	400	50	95	74	3P+T	10	16
SMOBICART3N	2/3	400	50	95	74	3P+N+T	10	16

 Gruppo carrellato per aspirazione e filtrazione di fumi di saldatura con braccio da 3 m Ø 150 mm, portata massima di 1.400 m³/h, efficienza di filtrazione 95% con filtri a tasche e carbone attivo.

 Mobile filtering and extracting unit for welding fumes with 3-m-long arm Ø 150 mm. Max airflow 1.400 m³/h, filtering efficiency of 95% with pocket filters and activated carbons.

 Système mobile pour l'aspiration et la filtration des fumées de soudure avec bras articulé de 3 m et 150 mm de diamètre. Débit max 1.400 m³/h avec filtres à poches et charbon actif.

 Fahrbares Absaug- und Filtergerät komplett mit Absaugarm DN 150 mm, 3 m lang. Förderleistung 1.400 m³/h, 4 Taschenfilter mit Agscheidegrad 95% und Aktivkohlen.

 Sistema móvil para aspiración y filtración de humo de soldadura, completo de brazo autoportante diámetro 150 mm y de 4 filtros en bolsas y carbón activo. Caudal máx. 1.400 m³/h. Eficiencia de filtración de 95%

SMOBIMAX 2B



2.500 m³/h

SMOBIMAX	Kw/HP	V	Hz	%	dB	elettr.	m ²	Kg Carb
SMOBIMAX2B	2/3	400	50	95	74	3P+T	10	16

 Gruppo carrellato per aspirazione e filtrazione di fumi di saldatura con 2 bracci da 3 m Ø 150 mm, portata massima di 2.500 m³/h, efficienza di filtrazione 95% con filtri a tasche e carbone attivo.

 Mobile filtering and extracting unit for welding fumes with 2 3-m-long arms Ø 150 mm. Max airflow 2.500 m³/h, filtering efficiency of 95% with pocket filters and activated carbons.

 Système mobile pour l'aspiration et la filtration des fumées de soudure avec 2 bras articulés de 3 m et 150 mm de diamètre. Débit max 2.500 m³/h avec filtres à poches et charbon actif.

 Fahrbares Absaug- und Filtergerät komplett mit 2 Absaugarmen DN 150 mm, 3 m lang. Förderleistung 2.500 m³/h, 4 Taschenfilter mit Agscheidegrad 95% und Aktivkohlen.

 Sistema móvil para aspiración y filtración de humo de soldadura, completo de 2 brazos autoportante diámetro 150 mm y de 4 filtros en bolsas y carbón activo. Caudal máx. 2.500 m³/h. Eficiencia de filtración de 95%

SMOBIMAXPACK



SMOBIMAXPACK	nr. filt.	Kg. Carb.	SMOBIMAXPACK	%	Kg. Carb.
SMOBIMAXPACK	5	16	SCINT	65	-
			PREF22	85	-
			MF95/V	95	-
			CARB1 (2X)	-	16

 Set di filtri di ricambio per SMOBIMAX con spegniscintille, pre-filtro sintetico, cella filtrante ad alta efficienza e pannelli con carboni attivi.

 Set of spare filters for SMOBIMAX, with spark arrestor, synthetic pre-filter, high efficiency main filtering unit and activated carbon panels.

 Kit de filtres de rechange pour SMOBIMAX avec barrière anti-étincelles, préfiltre synthétique, cellule filtrante à haut rendement et panneaux à charbon actif.

 Satz von Ersatzfiltern für SMOBIMAX mit Funken Abschalter, synthetischem Vorfilter, Hauptfiltereinheit, Aktivkohlenpaneele.

 Conjunto de filtros de repuesto para SMOBIMAX con barrera antichispas, prefiltro sintético, filtro de alta eficiencia y paneles de carbón activo.

SMOBIJET



1.500 m³/h

SMOBIJET	Kw/HP	V	Hz	%	dB	elettr.	m ²	Kg Carb
SMOBIJET1503	2/3	400	50	99,9	74	3P+T	20	-
SMOBIJET1503N	2/3	400	50	99,9	74	3P+n+T	20	-

 Gruppo carrellato per aspirazione e filtrazione di fumi di saldatura e polveri di molatura con braccio da 3 m ø150 mm, portata massima di 1.500 m³/h, efficienza di filtrazione 99,9% con 2 filtri a cartucce e pulizia semi automatica.

 Mobile filtering and extracting unit for welding fumes and grinding dust with 3-m-long arm ø150 mm. Max airflow 1.500 m³/h, filtering efficiency of 99,9% with 2 cartridge filters.

 Système mobile pour l'aspiration et la filtration des fumées de soudure avec bras articulé de 3 mt et 150 mm de diamètre. Débit max 1.500 m³/h avec 2 filtres a cartouches.

 Fahrbares Absaug-und Filtergerät komplett mit Absaugarm DN 150 mm, 3 mt lang. Förderleistung 1.500 m³/h, 2 Patronenfilter mit Agscheidegrad 99%.

 Sistema móvil para aspiración y filtración de humo de soldadura, completo de brazo autoportante diámetro 150 mm y de 2 filtros en cartucho. Caudal máx. 1.500 m³/h. Eficiencia de filtración de 99%

SMOBIJET200



2.000 m³/h

SMOBIJET	Kw/HP	V	Hz	%	dB	elettr.	m ²	Kg Carb
SMOBIJET2003	2/3	400	50	99,9	74	3P+T	30	-
SMOBIJET1503C	2/3	400	50	99,9	74	3P+T	30	16

 Gruppo carrellato per aspirazione e filtrazione di fumi di saldatura e polveri di molatura con braccio da 3 m ø200 mm, portata massima di 2.000 m³/h, efficienza di filtrazione 99,9% con 3 filtri a cartucce e pulizia semi automatica.

 Mobile filtering and extracting unit for welding fumes and grinding dust with 3-m-long arm ø 200 mm. Max airflow 2.000 m³/h, filtering efficiency of 99,9% with 3 cartridge filters.

 Système mobile pour l'aspiration et la filtration des fumées de soudure avec bras articulé de 3 mt et 200 mm de diamètre. Débit max 2.000 m³/h avec 3 filtres a cartouches.

 Fahrbares Absaug-und Filtergerät komplett mit Absaugarm DN 200 mm, 3 mt lang. Förderleistung 2.000 m³/h, 3 Patronenfilter mit Agscheidegrad 99,9%.

 Sistema móvil para aspiración y filtración de humo de soldadura, completo de brazo autoportante diámetro 200 mm y de 3 filtros en cartucho. Caudal máx. 2.000 m³/h. Eficiencia de filtración de 99,9%

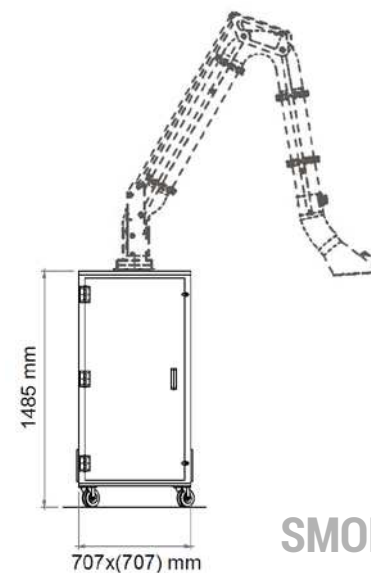

SMOBIMAX

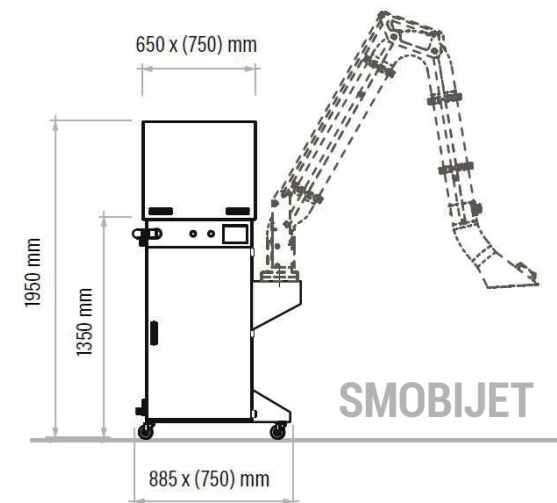

SMOBIJET